

OPERATING INSTRUCTIONS

KEROSENE COOKING STOVE

MODEL K-30F



KEROSENE ONLY

INSPECTION AND PRECAUTION BEFORE OPERATION

- 1) Remove the cooking stove from the carton box, and then remove the protective cardboard.
- 2) Turn the knob clockwise to check if the wick moves up and down uniformly and smoothly to a height of 7 mm above the wick adjuster.
- 3) Do not use the cooking stove without the cooking guard.
- 4) Do not install the cooking stove on an unstable place.
- 5) Keep away from children, furniture and clothing.
- 6) Always make sure that there is sufficient ventilation and use the cooking stove in well-ventilated areas.
- 7) Do not move the cooking stove when it is burning or still hot.
- 8) Do not step on or sit on the cooking stove.
- 9) Do not operate the cooking stove in areas exposed to drafts.

FUELING



- 1) Remove the fuel tank cap.
- 2) Fill the fuel up to the "F" marking by siphon pump. Do not exceed feeding over this level.
- 3) After filling the tank, replace the fuel tank cap on the tank inlet, and make sure that it is firmly placed.
- 4) If any fuel is spilled, wipe it dry with a cloth.

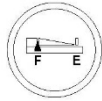

WARNING: Never use any fuel other than water clear and high quality of kerosene. Never use **GASOLINE!** Use of such fuels can result in explosion and/or fire and cause injury. **ALWAYS** extinguish stove before refill fuel tank. Never refill fuel tank when stove is operating or still hot. Never store the fuel in a place that children can reach. Do not move, refuel or attempt to service your stove while it is burning or still hot. Use stove only in well-ventilated areas.

LIGHTING PROCEDURE



- 1) Turn the wick adjuster knob clockwise as far as possible to raise the wick.



- 2) Raising the chimney prong on the lower part of the heat chamber, put the match-light to the wick.



- 3) Check to insure that the heat chamber is properly placed on the wick adjuster, and that the wick is not jammed in the heat chamber by moving the heat chamber prong lightly to the right and left, if the wick is cramped in the heat chamber, the stove may emit smoke.

FLAME ADJUSTMENT



- 1) In one minute after lighting, blue flame comes up from the top of the heat chamber.
- 2) If the flame rises high and burns under red flame, turn the wick adjuster knob counter-clockwise and lower the wick to change into blue flame.
- 3) Do not use too weak a flame. Even when using very low flame, adjust the flame so that it rises above the top of the heat chamber. If the flame is too low and only burns inside the heat chamber, the simmering flame will quickly damage the heat chamber, and will produce an oily smell.

WARNING: ALWAYS place the pan on the center of the cooking guard.

TURNING UNIT OFF



Turn the wick adjuster knob counter-clockwise until it stops. The flame will go out in a short time. After turning off the stove, check to make sure that the flame is completely out.

WARNING: If it is difficult to turn the wick adjuster knob counter-clockwise, burn out until no fuel remains or extinguish the flame by putting water on the heat chamber. If the stove tipped over, raise the stove without panic. Be aware of the burn injury.

REPLACING THE WICK



- 1) Remove the cooking guard and heat chamber.



- 2) Unscrew the four (4) wing nuts on the tank.



- 3) Remove the wick adjuster upward.

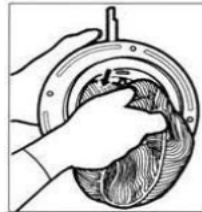

- 4) Remove the old wick from the wick adjuster by folding it.

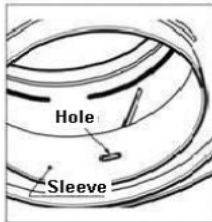

- 5) Align the three (3) opening in the wick adjuster: 1) the holes in the sleeves, 2) the diagonal slots in the fixed part of the wick adjuster, and 3) the slots in the moving part of the wick adjuster controlled by the wick adjuster knob.



- 6) Fold the new wick in quarters and insert it into the wick adjuster from the wick adjuster bottom. Place one of the pins in one of the line-up openings. If you experience difficulty, gently turn the wick adjuster clockwise. Then insert the two other pins, turning the wick adjuster knob if necessary. Do not bend the sleeve.

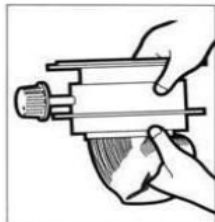

- 7) Gently press the wick, all along its circumference, against the wick adjuster to insure that it is firmly in place.



- 8) Open the lower part of the wick adjuster and set the wick adjuster assembly on the tank carefully. Do not allow a loose wick to come out of the tank.



- 9) Screw the four (4) wing nuts tightly. Turn the knob to the right and left to check if the wick moves smoothly.



- 10) Replace the heat chamber, the wick adjuster knob and the cooking guard.

BE SURE TO ALWAYS USE GOOD QUALITY KEROSENE

If old or impure kerosene is used, the stove will not function properly. Poor quality kerosene will cause a large amount of tar to accumulate on the top of the wick, and raising and lowering the wick will not be smooth.

The Reason: Poor quality kerosene will cause carbide particles to accumulate even on a clean and well-trimmed wick, making it difficult to raise and lower the wick.

PROPER STORAGE OF KEROSENE

1. If kerosene is stored outdoors in plastic containers during the hot summer season: heat, oxidation and ultra-violet rays will cause the quality to become poor.
2. If kerosene is stored in a sunny location for a long period of time, the quality will become poor.
3. If a small quantity of kerosene is stored in a large container during the summer season, the quality will become poor.

CLEANING THE HEAT CHAMBER

If the innumerable small holes inside of the heat chamber become plugged because of food boiling over, the flame will not burn properly. Clean the heat chamber holes by using a brush.

CLEANING THE WICK

1. Indications that the wick may need attention are:
 - Low flame
 - Tar deposit on the top edge of the wick
 - Difficulty in turning the wick adjuster knob
 - A flickering or dying flame
2. Clean the wick by burning dry as follows:

When the fuel gauge indicates empty, but the heater is still burning, raise the wick to its highest position and allow the flame to consume the remaining fuel in tank.

Note: Burning the wick dry can at times create odors. For the burning dry procedure, remove your heater from the living area of your house into a well-ventilated area such as a garage or even a sheltered area outside. If you burn the wick dry outside, be sure that heater is not exposed to strong drafts during the procedure.

ALWAYS KEEP IN MIND THAT GOOD QUALITY KEROSENE IS ESSENTIAL FOR GOOD OPERATION OF KEROSENE COOKING STOVE.

PARTS LIST

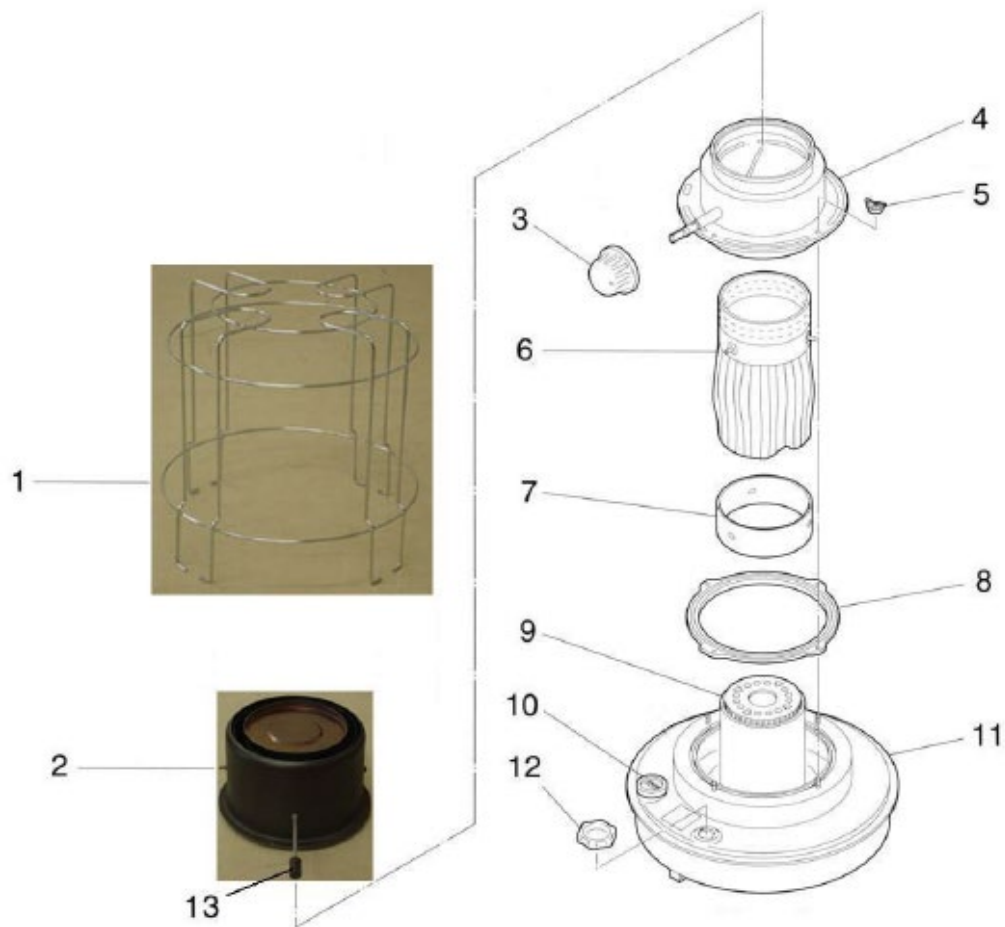

1.	Cooking Guard	8.	Rubber Packing
2.	Heat Chamber	9.	Primary Air Tube Cover
3.	Wick Adjuster Knob	10.	Fuel Gauge
4.	Wick Adjuster	11.	Fuel Tank
5.	Wing Nut	12.	Fuel Tank Cap
6.	Glass Fiber Wick	13.	Chimney Prong
7.	Wick Sleeve		

SPECIFICATION:

Dimensions	Width	342 mm
	Depth	342 mm
	Height	315 mm
Weight		3,5 kg
Tank Capacity		4,0 ℓ
Heat Rating		2,25 kW (7,700 BTU/h)
Fuel Consumption		0,209 ℓ/h
Burning Time		19.0 h